



### Nominal data

Type	4318	
Nominal voltage	VDC	48
Nominal voltage range	VDC	36 .. 53
Speed (rpm)	min <sup>-1</sup>	2800
Power consumption	W	5.1
Min. ambient temperature	°C	-20
Max. ambient temperature	°C	75
Air flow	m <sup>3</sup> /h	170
Sound power level	B	5.8
Sound pressure level	dB(A)	45

ml = Max. load · me = Max. efficiency · fa = Free air · cs = Customer specification · ce = Customer equipment  
Subject to change

### Technical description

<b>Housing material</b>	Glass-fiber reinforced PBT plastic
<b>Impeller material</b>	Glass-fiber reinforced PA plastic
<b>Weight</b>	0.220 kg
<b>Dimensions</b>	119 x 119 x 32 mm
<b>Airflow direction</b>	Exhaust over struts
<b>Direction of rotation</b>	Clockwise, viewed toward rotor
<b>Storage</b>	Ball bearing
<b>Service life L10 at 40 °C</b>	62500 h
<b>Service life L10 at maximum temperature</b>	27500 h
<b>Cable</b>	Leads AWG 22, TR 64, stripped and tin-plated.
<b>Motor protection</b>	Protection against reverse polarity and blocked rotor.
<b>Locked-rotor protection</b>	Locked-rotor and overload protection
<b>Approval</b>	VDE, CSA, UL, CE
<b>Option</b>	Speed signal, alarm signal

## Product drawing

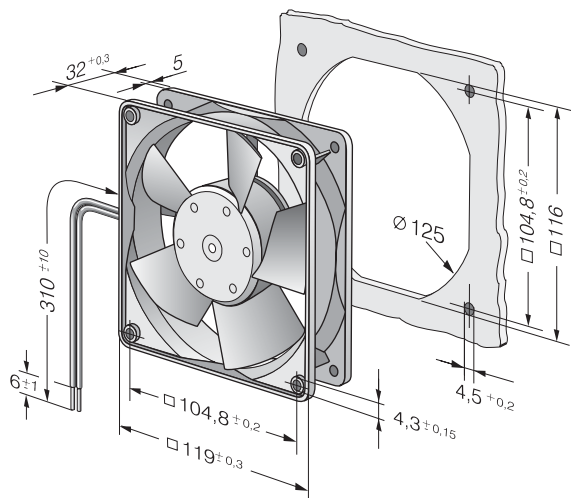

## Curves: Air performance

